

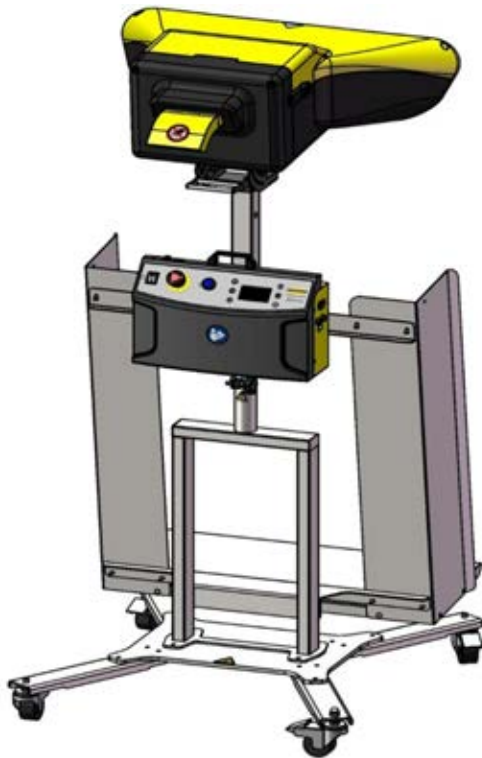

POWERED BY **NUEVOPAK**

# USER MANUAL

## X-Fill Pro



**Model: XFP-0-E / XFP-0-U / XFP-0-UK**

**Serial No.: XFP-**

Please attach the business card  
of your **Nuevopak/IPG** Representative here



**Table of Contents**

Table of Contents .....	i
Chapter 1 General Information .....	1
1.1 Revision Control .....	1
1.2 Preface .....	1
1.3 Dispenser, Stands, and Accessories Set-Up .....	1
1.4 Dispenser Product Description .....	1
1.5 Technical Support .....	2
1.6 Field Service Assistance .....	2
1.7 EC Declaration of Conformity / UK Conformity Assessed Marking .....	2
1.8 Definitions .....	2
Chapter 2 Dispenser Overview .....	3
2.1 Dispenser Identification .....	3
2.2 Important Safety Instructions .....	4
2.2.1 Symbol Used Throughout this User Manual .....	4
2.2.2 Safety Precaution .....	4
2.2.3 Personal Safety .....	4
2.2.4 Residual Risk .....	5
2.2.5 Operational Safety .....	5
2.2.6 Precautionary Statements .....	5
2.2.7 Warning Label Descriptions .....	5
2.2.8 Safety Components .....	5
2.2.9 Warning and Caution Labels .....	7
Chapter 3 Intended Use .....	8
3.1 Intended Use of X-Fill Pro Dispenser .....	8
3.1.1 Foreseeable Misuse .....	8
3.1.2 Disclaimer .....	8
Chapter 4 Dispenser Operations .....	10
4.1 Dispenser Specifications .....	10
4.1.1 Component Layout .....	10
Figure 3 Component Layout .....	10
4.1.2 Dispenser Specifications .....	11
4.2 Dispenser System Set-up .....	12
4.3 Dispenser Stand/Accessories Adjustments .....	13
4.3.1 Dispenser Accessories/Stands Overview .....	13
4.3.2 Floor Stand .....	14
4.3.2.1 Adjusting the Angle of the Dispenser Head .....	15
4.3.2.2 Rotational Positioning of the Dispenser Stand Positioner .....	17
4.3.2.3 Positioning of the Dispenser on Floor Stand for Operation .....	18
4.4 Dispenser Controls Layout and Operation .....	19
4.4.1 Dispenser Controls .....	19
4.4.2 Dispenser Modes of the X-Fill Pro .....	20
4.4.3 Feeding Paper into the Dispenser and Operating the Several Dispenser Modes .....	20
4.4.4. Feeding Mode Operation .....	21
4.4.5. Memory Mode Operation .....	21
4.4.6. Pre-Set Mode Operation .....	22
4.4.7. Cut and Hold Mode Operation .....	22
4.4.8. Program Length Mode .....	23
4.5 Dispenser Units Setting and Paper Feed Length Adjustment .....	25
4.5.1 Changing Dispenser Units Setting .....	25
4.5.2 Adjusting the Feed Length of the String of Void Fill Paper .....	25
4.6 Moving/Storing the Dispenser .....	27
4.6.1 Moving the Dispenser on Floor Stand .....	27

---

4.6.2 Storing the Dispenser Void Fill Paper System .....	27
Chapter 5 Dispenser Maintenance .....	28
5.1 Inspection, Maintenance, and Repair .....	28
5.2 Operator Weekly Inspection Interval .....	28
5.3 Preventive Maintenance Interval .....	29
Chapter 6 Troubleshooting .....	30
6.1 Troubleshooting .....	30

# Chapter 1 General Information

## 1.1 REVISION CONTROL

REV 1.2 ..... Pre-Release

## 1.2 PREFACE

This User Manual contains information necessary to operate the **X-Fill Pro** Dispenser and the various stands/accessories, and variants of the **X-Fill Pro**. It is intended for use by the **Installer** and **Operator** of the **Dispenser** to become familiar with the **X-Fill Pro** Dispenser. It is recommended to read this User Manual carefully before use. This User Manual applies to the product type: **XFP-0-E, XFP-0-U and XFP-0-UK**. The **X-Fill Pro Dispenser** will be referred to as **Dispenser** throughout this manual.

Please refer to the Table of Contents of this User Manual to locate the information relevant to you. Please be sure to keep this User Manual in a safe and convenient place, **close to the Dispenser**, to refer to it whenever necessary.

This User Manual is originally written in English. All other languages are translations of the original. For more information, or to order new User Manuals, please contact **Nuevopak**, an **IPG Company**, or an authorized representative.



**This X-Fill Pro User Manual contains important information related to safety, intention and meaning of the Dispenser labels, Dispenser operational modes and the general functions of the X-Fill Pro and its stand/accessories.**

## 1.3 DISPENSER, STANDS, AND ACCESSORIES SET-UP



**THE DISPENSER AND ITS ACCESSORIES MAY ONLY BE SET-UP BY AN OFFICIAL NUEVOPAK, AN IPG COMPANY, AUTHORIZED REPRESENTATIVE, OR A NUEVOPAK OR IPG COMPANY TRAINED SERVICE TECHNICIAN. THESE PARTIES ARE PROVIDED WITH THE DISPENSER SET-UP MANUAL.**

## 1.4 DISPENSER PRODUCT DESCRIPTION

The **Dispenser** converts a bundle of fan folded paper into a protective void fill and shock absorbing packaging material. The **Dispenser** is an electrically driven feeding dispenser that consists of a dispensing mechanism. In the **Dispenser**, the paper is formed into a protective void fill and shock absorbing packaging material through a folding and crumbling process. There are multiple variants of the **X-Fill Pro** machine designed for use in multiple countries and electrical systems.

## 1.5 TECHNICAL SUPPORT

If any problems arise with this **Dispenser** during the normal course of operation, your properly trained and qualified internal service personnel should be able to repair any issues after consulting Chapter 6, Troubleshooting.

## 1.6 FIELD SERVICE ASSISTANCE

For technical information and troubleshooting assistance, contact Technical Support. Internal qualified service personnel; please refer to the attached Business Card or the Identification Plate for contact information.

## 1.7 EC DECLARATION OF CONFORMITY / UK CONFORMITY ASSESSED MARKING

The EC Declaration of Conformity and the UK Conformity Assessed Marking are added to the User Manual as separate Addendum.

The language in which the EC Declaration of Conformity and UK Conformity Assessed Marking are written, originates from English. All other languages are translations from the original.

## 1.8 DEFINITIONS

Throughout this manual there are common terms and phrases used. They are listed below:

1. The **Dispenser** is defined as the **X-Fill Pro** which is manufactured by **Nuevopak**, an **IPG Company**.
2. **The Installer** is defined as that individual who has been trained by a **Nuevopak**, an **IPG Company**, representative and is authorized to install and operate the system as outlined in this User Manual.
3. The **Operator** or **User** is defined as that individual who has been trained by internal qualified service personnel or a **Nuevopak**, an **IPG Company**, representative and is authorized to operate the system as outlined in this guide.
4. An **Authorized Representative** or **Qualified Service Personnel** are defined as those individuals who are authorized to: install the Dispenser, operate the Dispenser, train users, train qualified service personnel, and to perform all maintenance and repair procedures other than those outlined in this User Manual.



**WARNING! ONLY QUALIFIED SERVICE PERSONNEL WHO HAVE BEEN TRAINED BY A NUEVOPAK REPRESENTATIVE ARE ALLOWED TO PERFORM MAINTENANCE AND REPAIR PROCEDURES OTHER THAN THE ONES DESCRIBED IN THIS MANUAL.**

# Chapter 2 Dispenser Overview

## 2.1 DISPENSER IDENTIFICATION

The **Dispenser** identification is located on the **Identification Plate** which is attached to the bottom cover of the **Dispenser Head** (refer to Figure 1).

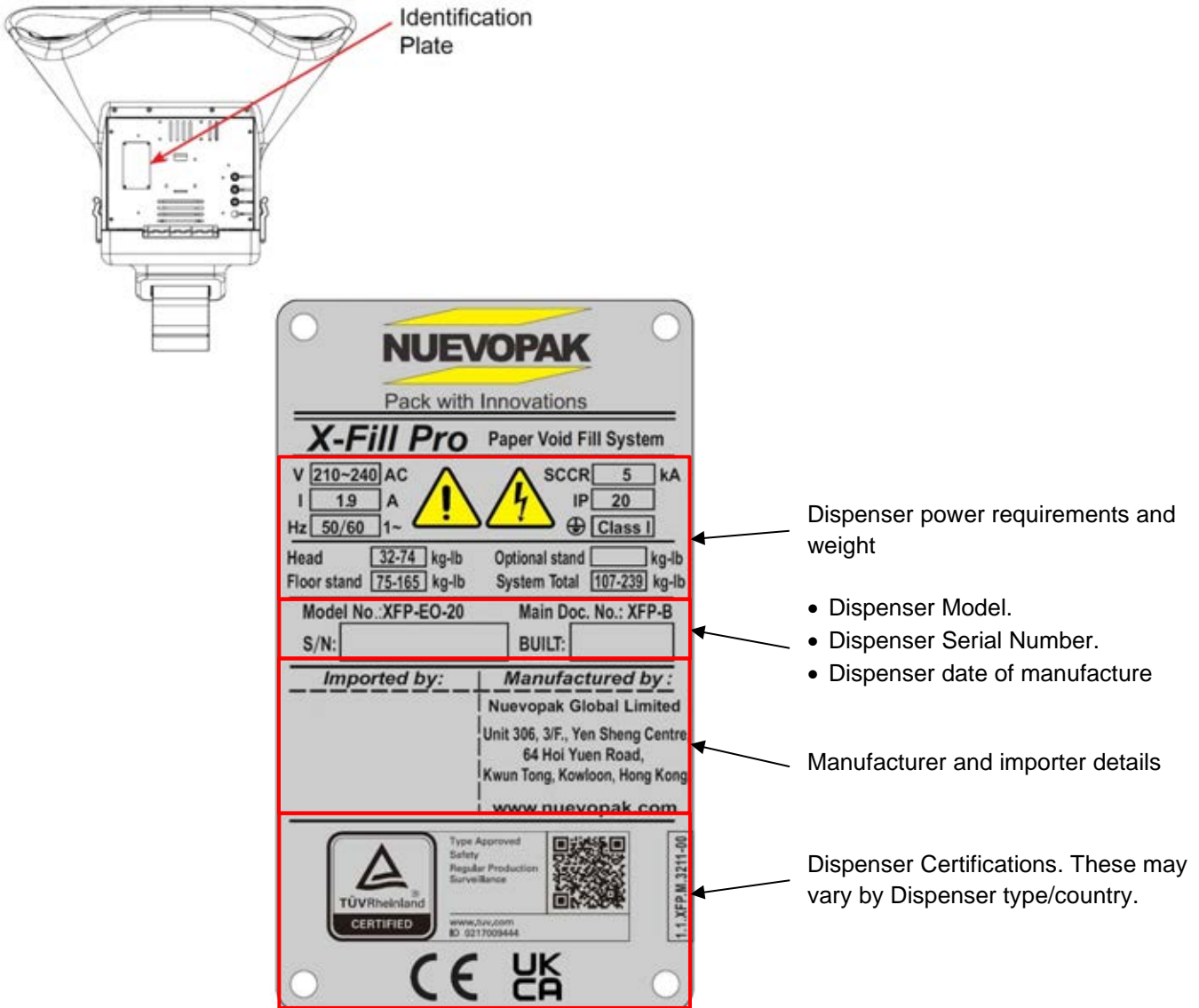

Figure 1 Dispenser Identification



## 2.2 IMPORTANT SAFETY INSTRUCTIONS

### 2.2.1 Symbol Used Throughout this User Manual



This symbol indicates required focus and attention on essential information or to indicate a potential hazard.

### 2.2.2 Safety Precaution



The Dispenser is designed for safe use in conformance with the application, conditions, and rules described in this User Manual. All users must read and understand this manual before operating the Dispenser.

### 2.2.3 Personal Safety



- Do not operate the Dispenser when Dispenser Control Box covers are damaged or removed.
- Do not operate the Dispenser with a damaged, disabled, or tampered safety system.
- Do not reach inside the Dispenser with the covers in place.
- The Warning and Caution labels attached to the Dispenser must always remain visible.
- Pay attention to sharp edges and pinch points of the Dispenser and its accessories.
- Keep the working area clean and free of obstacles.
- Take account of ergonomic principles when working with the Dispenser.
- Pay attention when using hand tools such as knives, scissors, etc., due to the risk of cutting.
- Make sure the working area is sufficiently lit.
- The Dispenser may only be operated by one person at a time.



In the event of a defect, or if the operation of the Dispenser differs from the descriptions in this User Manual, turn the I/O Main Switch to O [OFF] and disconnect the Main Power Cord Plug from the main power until the unit can be inspected by a trained Nuevopak, an IPG Company, representative or qualified service personnel.

### 2.2.4 Residual Risk



**WARNING! KEEP CLOTHING, HAIR, AND JEWELRY OUT OF THE DISPENSER INPUT AND OUTPUT CHUTE. KEEP HANDS AWAY FROM THE PAPER WHEN THE DISPENSER IS OPERATING. PAPER EDGES MAY CUT THE SKIN.**



**WARNING! THIS DISPENSER CONTAINS AN AUTOMATIC CUTTING BLADE. FAILURE TO FOLLOW THE SAFETY PROTOCOLS IN THIS MANUAL CAN RESULT IN SERIOUS INJURY OR BODILY HARM .**

### 2.2.5 Operational Safety



- Make sure that cords cannot be and are not damaged.
- Before moving the Dispenser, unplug the Main Power Cord Plug and Foot Switch Plug from the Dispenser Control Box and secure loose cords.
- Make sure the Dispenser is acclimated for at least 30 minutes when moved from a cold area.
- Do not use cable reels. An extension cable with a wire gauge of at least 14 AWG (1.5mm<sup>2</sup>) with a maximum length of 11.5 ft. (3.5 m) may be used.

### 2.2.6 Precautionary Statements

There are several Warning and Caution labels used on the **Dispenser**; these labels are placed at different locations on the **Dispenser** to warn the Installer, Operator(s) and Service Personnel of possible dangers (refer to Figure 2). Please refer to this User Manual of the **X-Fill Pro** to get familiar with the meaning of the Warning and Caution labels on the **Dispenser** before using the **Dispenser**.

### 2.2.7 Warning Label Descriptions

The **Dispenser**, the stand(s) and its accessories are provided with Warning and Caution labels. **Do not remove any WARNING or CAUTION labels** and keep them undamaged. In case a Warning or Caution label is damaged, contact **Nuevopak**, an **IPG Company**, or an authorized representative for replacement labels.

### 2.2.8 Safety Components



**WARNING! DO NOT REMOVE OR TAMPER WITH THE SAFETY COMPONENTS. DO NOT REMOVE THE COVERS. THE ACCESS COVERS MAY ONLY BE REMOVED BY AN AUTHORIZED NUEVOPAK/IPG REPRESENTATIVE OR QUALIFIED SERVICE PERSONNEL THAT HAVE BEEN TRAINED BY A NUEVOPAK/IPG REPRESENTATIVE.**

The following is a list (refer to Table 2) and illustration (refer to Figure 2) of the safety components and warning labels which are part of the **Dispenser**.

**Table 1 Safety Components**

Safety Component	Description
Emergency Stop Button (E-Stop)	This switch, located on the control box, interrupts the power to the driven motor when pushed.
Covers	Front, Top, and Bottom Covers prevent user access to the moving parts of the Dispenser during operation.
Control Box Cover	The Control Box Cover prevents user access to the electronic parts of the Dispenser during operation.
Fuse	4 Amp, 250 Volt, 5mm x 20mm

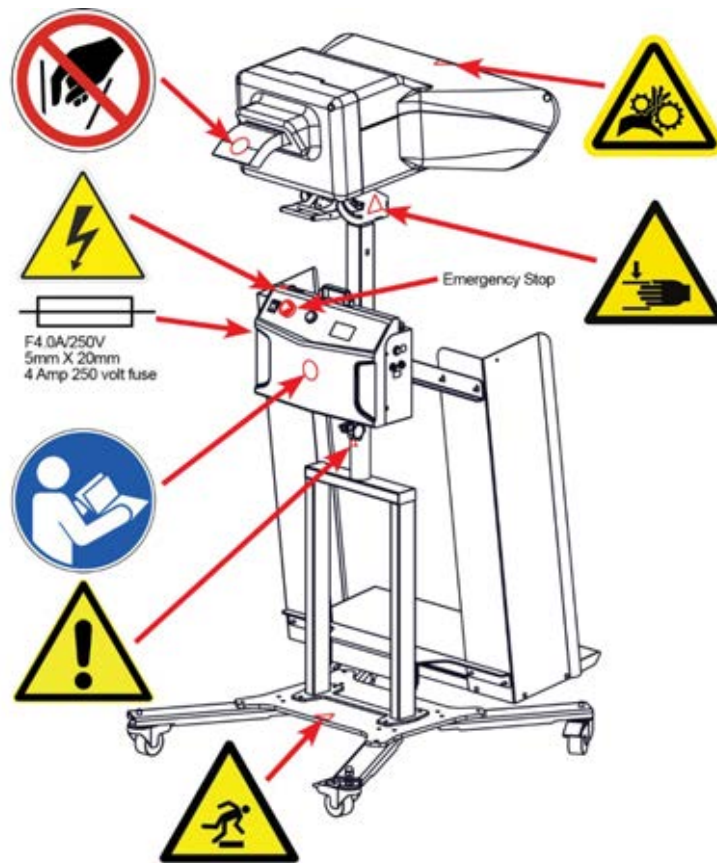

**Figure 2 Dispenser Warning Labels Location.**

## 2.2.9 Warning and Caution Labels

Information symbols used throughout this manual:

**Table 2 Warning and Caution Labels**

SYMBOL	MEANING
	This “ <b>READ MANUAL</b> ” symbol calls attention to the importance of reading and understanding the provided User Manual.
	This “ <b>GOGGLES</b> ” symbol calls attention to the need to wear protective eyewear while performing maintenance and repair procedures.
	This “ <b>EAR PROTECTION</b> ” symbol calls attention to the need to wear ear protection during operation.
	This “ <b>DISCONNECT POWER</b> ” symbol indicates the need to disconnect the main plug for maintenance purposes, in case of malfunction, or when the Dispenser is left unattended.
	This “ <b>GLOVES</b> ” symbol calls attention to the need to wear protective gloves while performing maintenance and repair procedures.
	This “ <b>TRIANGLE</b> ” symbol calls attention to special notes that will enhance operating and maintenance procedures.
	This “ <b>DO NOT PUSH</b> ” symbol indicates to not push against the dispenser when in operation.
	This “ <b>EXCLAMATION POINT</b> ” symbol calls attention to equipment features that you should be familiar with by reading the enclosed literature. This will help prevent operating problems.
	This “ <b>BOLT OF LIGHTNING</b> ” symbol indicates that there is non-insulated material within your unit that may cause an electric shock. Disconnect all electric power including remote disconnects before servicing.
	This “ <b>ENTRAPMENT</b> ” symbol indicates that there are paper forming gears within your unit that can cause injury. Keep hands clear during operation.
	This “ <b>SHARP</b> ” symbol indicates sharp points in the Dispenser to be aware of to avoid injury.
	This “ <b>PINCH POINT</b> ” symbol indicates to take care to avoid injury to hands when in the surrounding area of equipment with closing or adjusting mechanical parts.
	This “ <b>TRIP</b> ” symbol brings attention to take care when in the surrounding area of an un-level floor or wheretripping hazards exist.

## Chapter 3 Intended Use

### 3.1 INTENDED USE OF X-FILL PRO DISPENSER



The Dispenser is for intermittent use and should not be run continuously for more than one minute.



**CAUTION! USING THE DISPENSER BEYOND ITS CAPABILITY, BEYOND THE PHYSICAL USER CONDITIONS, OR WITHOUT FOLLOWING THE SAFETY PRECAUTIONS AS DESCRIBED IN THE SET-UP MANUAL AND THIS USER MANUAL CAN BE CONSIDERED AS MISUSE.**



**CAUTION! READ THIS USER MANUAL BEFORE STARTING WORK OR BEFORE OPERATING THE DISPENSER .**

1. The void fill product created by the **Dispenser** is intended to be used only as packaging material.
2. Only void fill paper products which are intended to be used by the **Dispenser** and which are supplied by a **Nuevopak**, an **IPG Company**, authorized representative may be used.
3. Only accessories which are intended to be used by the **Dispenser** and which are supplied by a **Nuevopak**, an **IPG Company**, authorized representative may be used.
4. Connect the **Dispenser** to a properly grounded outlet **only**.
5. To disconnect, turn the **I/O Main Switch** to **O [OFF]** and disconnect the Main Power Cord Plug from the main power outlet.
6. Do not unplug cables by pulling on cord. To unplug grasp the plug, not the cord.

#### 3.1.1 Foreseeable Misuse

The following applications or acts are not suitable for the **Dispenser** and constitute improper use:

1. **DO NOT** use a paper void fill product other than those produced and supplied by a **Nuevopak** or **IPG Company** representative and intended for use in the **Dispenser**.
2. **DO NOT** use outside or in humid conditions.
3. **DO NOT** use in potentially explosive environments.
4. **DO NOT** wash or clean the **Dispenser** with excessive quantities of water.
5. **DO NOT** stand or hang from the **Dispenser** or its stand/accessories.
6. **DO NOT** place objects against or on top of the **Dispenser**.
7. **DO NOT** move the **Dispenser** while the power plug is still connected to the AC power supply.

#### 3.1.2 Disclaimer

The intended use of the **Dispenser** is to convert paper from a paper bundle into void fill material. **Nuevopak**, an **IPG Company**, and its authorized representatives are not responsible for any accidents, damages, or errors caused by:

1. Not following the instructions and illustrations as described in this **Dispenser** User Manual.

2. Use of components which are not supplied by **Nuevopak**, an **IPG Company**, or an authorized representative.
3. Repairs or modifications done by anyone other than a **Nuevopak**, an **IPG Company**, authorized representative or a **Nuevopak**, an **IPG Company**, trained Service technician.
4. Improper use or alternation to any of the original parts of the **Dispenser**.
5. Not keeping the **Dispenser** covers attached with the provided tamper-proof screws.



**WARNING! DO NOT REMOVE OR TAMPER WITH THE SAFETY COMPONENTS. DO NOT REMOVE THE FIXED COVERS. THE ACCESS COVERS MAY ONLY BE REMOVED BY AN AUTHORIZED NUEVOPAK/IPG REPRESENTATIVE OR QUALIFIED SERVICE PERSONNEL THAT HAVE BEEN TRAINED BY A NUEVOPAK/IPG REPRESENTATIVE.**



**CAUTION! TINNITUS OR TIREDNESS DUE TO NOISE EMISSION DURING OPERATION MAY OCCUR. PLEASE REFER TO THE TECHNICAL SPECIFICATION TABLE (TABLE 3) FOR THE MAXIMUM SOUND PRESSURE LEVEL GENERATED BY THIS DISPENSER. CONSULT YOUR COMPANY HEALTH AND SAFETY DEPARTMENT AS WEARING EAR PROTECTION MAY BE MANDATORY OR RECOMMENDED.**

## Chapter 4 Dispenser Operations

### 4.1 DISPENSER SPECIFICATIONS

#### 4.1.1 Component Layout

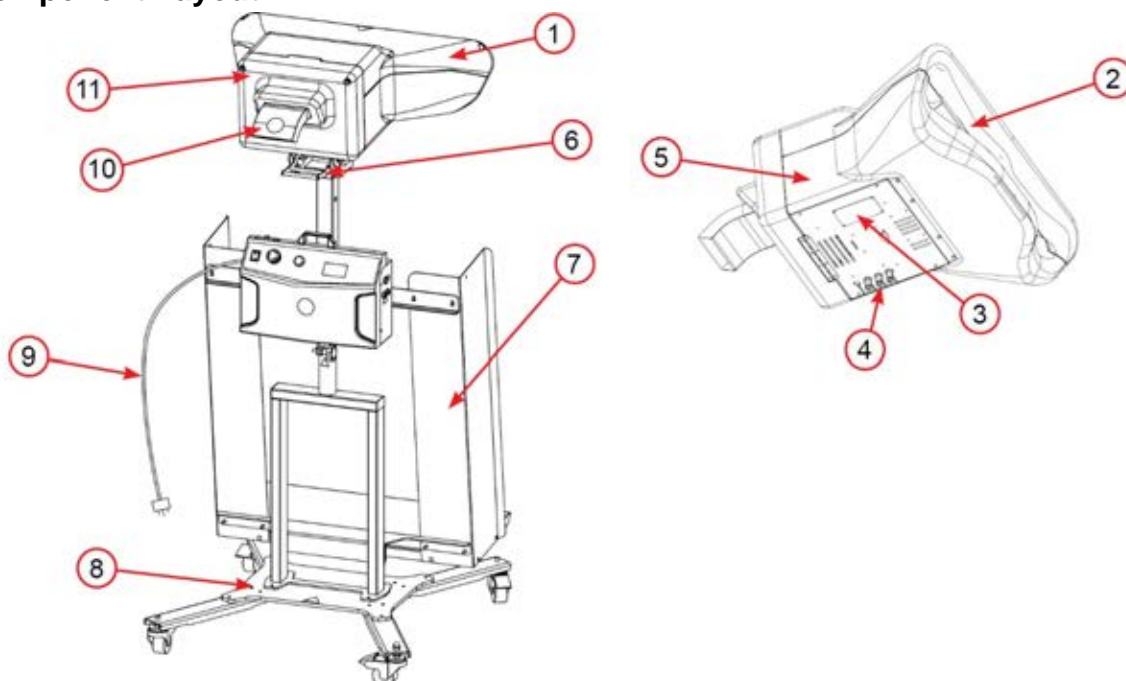

LEGEND	
Item No.	Description
1	Top Cover
2	Dispenser Input Chute
3	Identification Plate
4	Power Connections to Control Box
5	Bottom Cover
6	Dispenser Head Angle Adjustment
7	Paper Bundle Holder
8	Dispenser Accessories (Floor Stand Shown)
9	Main Power Cable
10	Dispenser Output Chute
11	Front Cover

Figure 3 Component Layout

### 4.1.2 Dispenser Specifications

**Table 3 Dispenser Specifications**

Component	Specification
Dispenser Head	
Dimensions	792 mm x 808 mm x 318 mm (31.2" x 31.8" x 12.5")
Weight	32.9 kg (73 lbs.)
Floor Stand, Accessory	
Dimensions	826 mm x 904 mm x 1552 mm (32.5" x 35.6" x 61.1")
Weight	75 kg (165 lbs.)
Maximum Weight of Bundle	96 kg (211.6 lbs.)
Maximum Sound Pressure Level	81.1dB(A) +/- 2.5dB(A)
Non-Ionizing Radiation	Not applicable
IP Class	IP20
Installation Class	Class I
Supply Voltage (U)	100 – 240, 1PH
Frequency	50-60 Hz
Current (I)	1.9 A (240VAC), 3.8 A (110VAC)
Power (P)	300 W (240VAC), 300 W (110VAC)
Fuse Rating (A)	5 A (240VAC), 5 A (110VAC)
Electric Receptacle	16 A (230VAC)
Electric Receptacle	15 A (110VAC)
Dispenser Color	Grey and Yellow
Dispenser Head Mechanical Construction	Metal frame with plastic covers
Accessories Mechanical Construction	Steel
Storage Temperature	-13 - 131°F (-25 - 55°C)
Operating Temperature	41 - 104°F (5 - 40°C)
Storage Humidity	"dry" ~ 95% (in protective packaging)
Operating Humidity	30 ~ 90%, non-condensing
Lighting	Normal. The Dispenser is not provided with lighting.
The electrical equipment shall be capable of operating correctly when the relative humidity does not exceed 90% at a maximum temperature of 20°C.	
Electrical equipment shall be capable of operating correctly at altitudes up to 6,562 ft. (2000m) above mean sea level.	



## 4.2 DISPENSER SYSTEM SET-UP

Required for safe use of the Dispenser by the Operator; make sure the Dispenser gets installed by the Installer according to the Operational Limits as shown below.



**WARNING! MAKE SURE THERE IS ONLY ONE PERSON PRESENT IN THE WORK AREA WHEN THE DISPENSER IS OPERATED.**

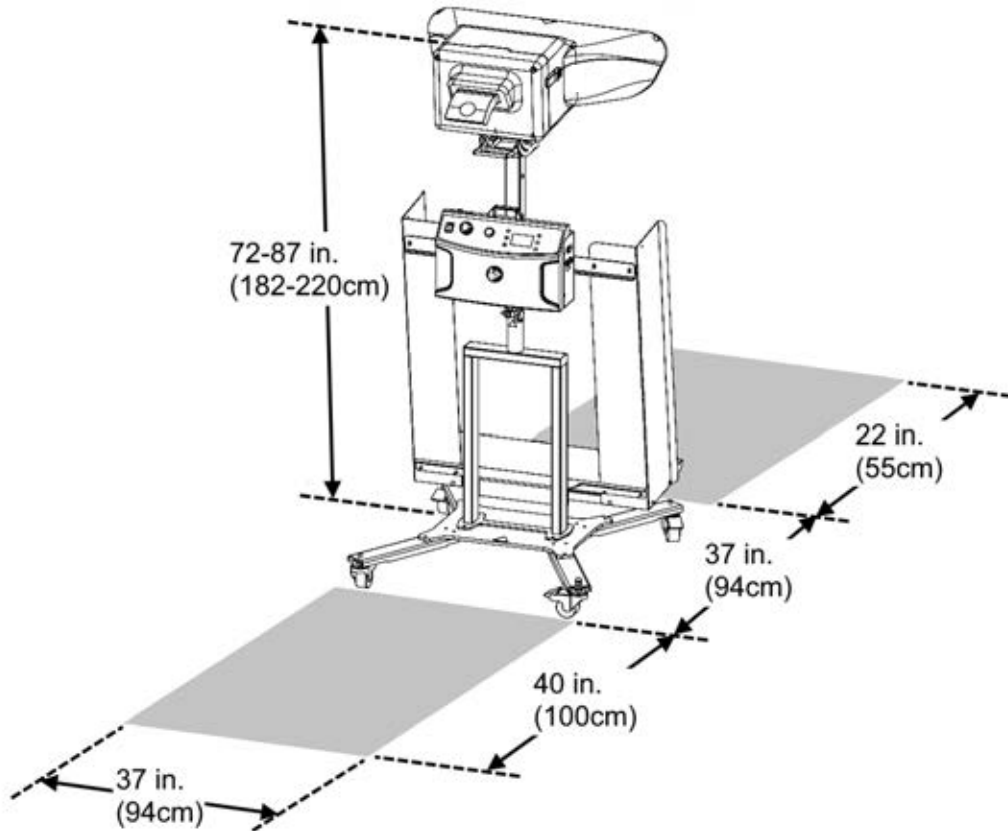

Figure 4 Floor Stand Set-Up

**WARNING! FAILURE TO PROPERLY GROUND THE SYSTEM COULD CREATE AN ELECTRIC SHOCK HAZARD.**



A qualified electrician should be consulted if there is any doubt as to whether a main power wall socket is properly grounded.



Do not use outdoors.

**WARNING! NEITHER THE DISPENSER NOR ITS ACCESSORIES ARE INTENDED FOR USE WITH OR AROUND POTENTIALLY FLAMMABLE OR EXPLOSIVE MATERIALS.**

## 4.3 DISPENSER STAND/ACCESSORIES ADJUSTMENTS

### 4.3.1 Dispenser Accessories/Stands Overview

The **Dispenser** can be set-up with the following accessories:

1. Floor Stand (refer to Figure 5).



**NOTE:** The available stands/accessories depend on the Dispenser configuration ordered.

**4.3.2 Floor Stand**

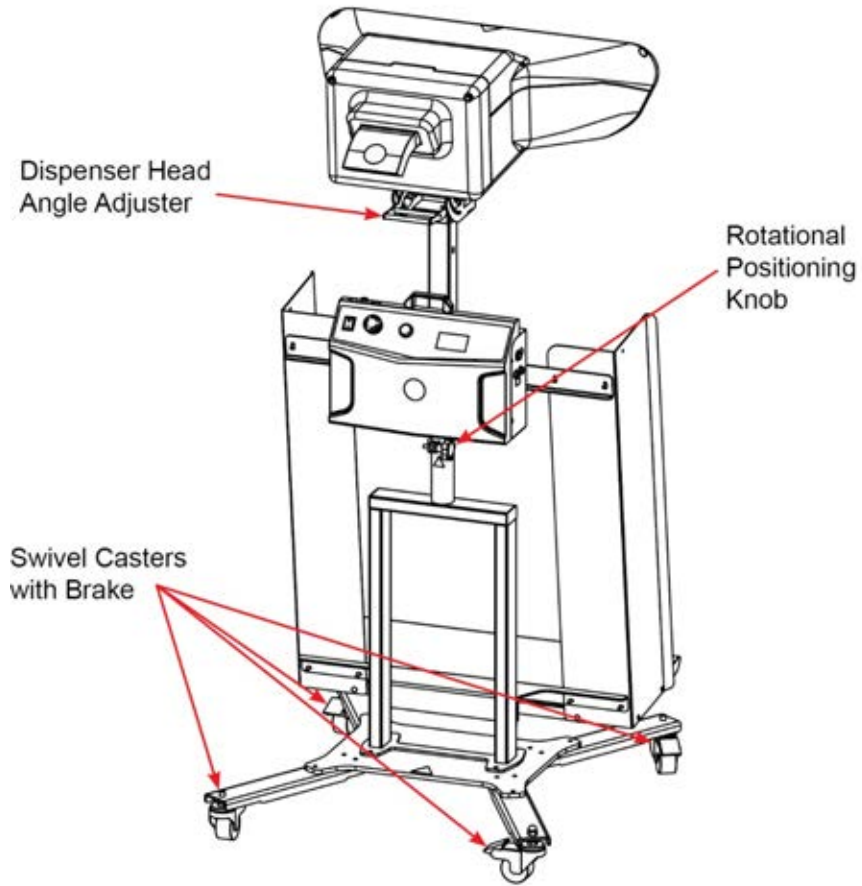

**Figure 5 Floor Stand**

### 4.3.2.1 Adjusting the Angle of the Dispenser Head



**CAUTION! WHEN ADJUSTING THE MACHINE BE AWARE OF PINCH POINTS AND MOVING PARTS.**

1. Hold the **Dispenser** head with one hand (refer to Figure 6).

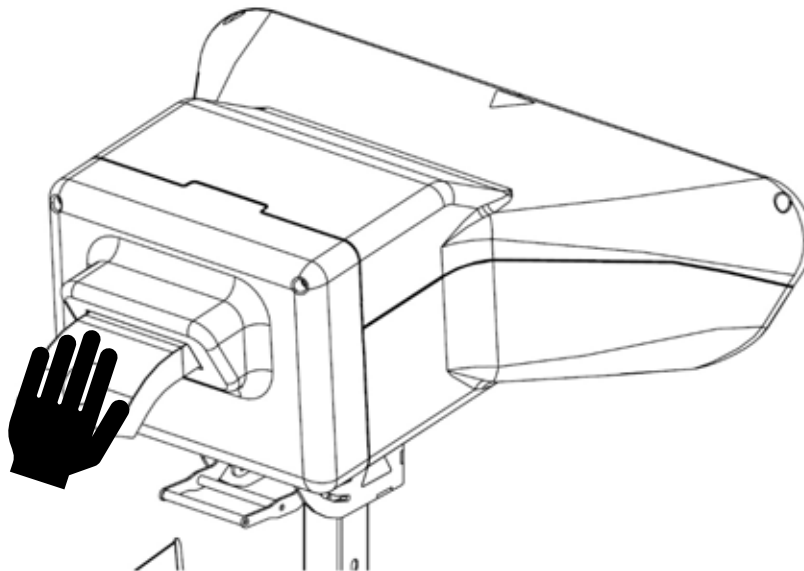

**Figure 6 Dispenser Head**

2. Pull the **Dispenser** Head Angle Adjuster Handle down with one hand (refer to Figure 7).

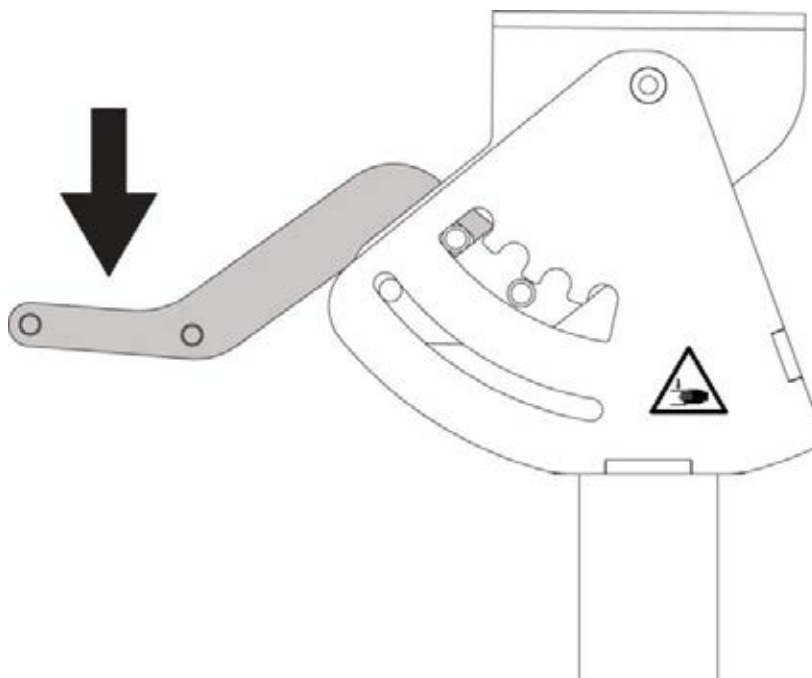

**Figure 7 Dispenser Head Angle Adjuster Handle**

3. Release the **Dispenser** Head Angle Adjuster Handle when the preferred angle is reached (refer to Figure 8).

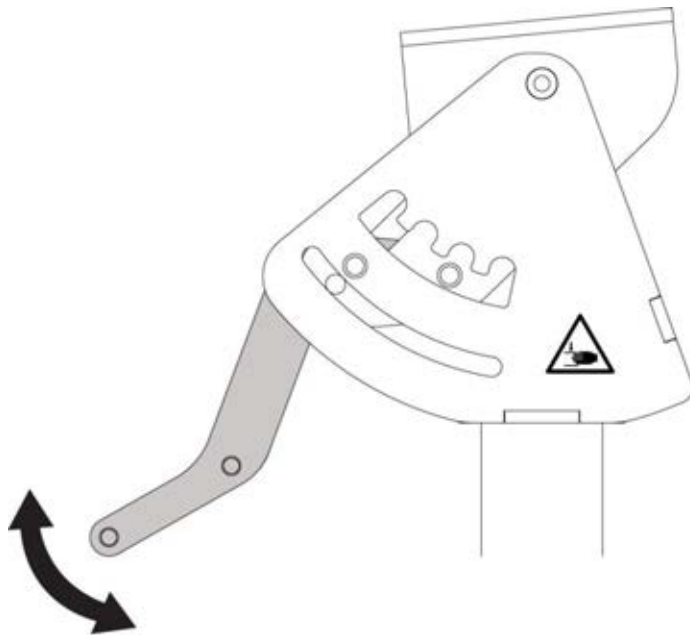

**Figure 8 Release the Dispenser Head Angle Adjuster Handle**

4. Make sure the **Dispenser** Head Angle Adjuster Handle is locked correctly (refer to Figure 9).

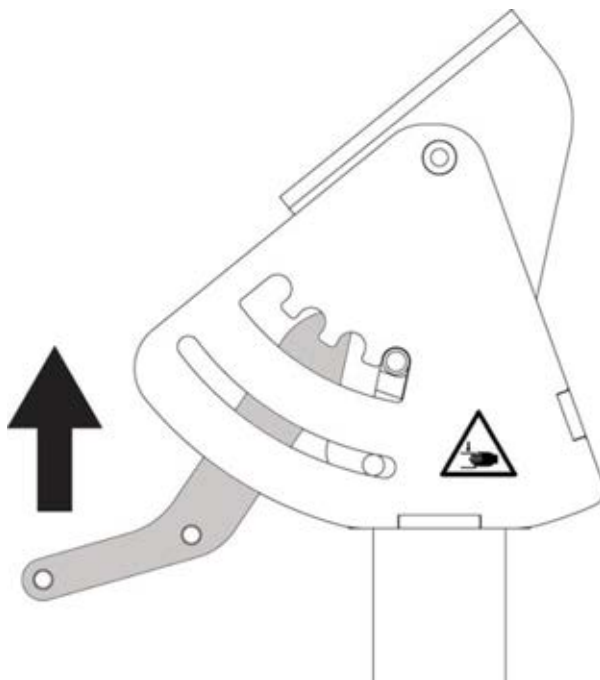

**Figure 9 Dispenser Head Angle Adjuster Handle Locked**

#### 4.3.2.2 Rotational Positioning of the Dispenser Stand Positioner

1. Turn the Rotational Positioning Knob three turns counterclockwise to loosen the **Dispenser Head** (refer to Figure 5).
2. Rotate the **Dispenser Head** to the preferred Output Chute position (refer to Figure 10).

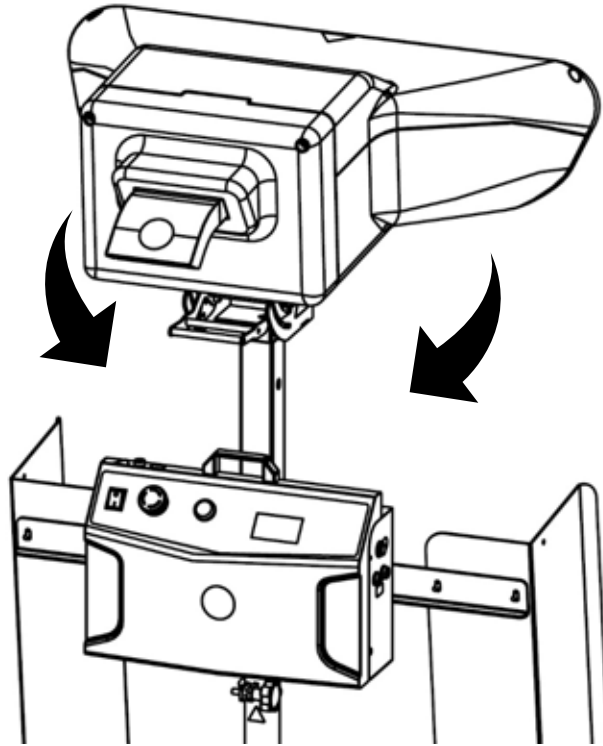

**Figure 10 Output Chute Position**

3. Tighten the Rotational Positioning Knob by turning it clockwise (refer to Figure 5).

#### 4.3.2.3 Positioning of the Dispenser on Floor Stand for Operation



**TAKE CARE TO AVOID UNEVEN FLOORS AND OBSTACLES IN THE SURROUNDING AREA. POTENTIAL TRIPPING HAZARD MAY EXIST. PERSONAL INJURY CAN OCCUR.**

**PROHIBITED! PUSHING AGAINST THE DISPENSER OR ACCESSORIES WHEN STATIONARY OR FIXATED. PERSONAL INJURY CAN OCCUR.**



**CAUTION! STANDING ON OR HANGING FROM THE DISPENSER OR ITS STAND/ACCESSORIES CAN CAUSE PERSONAL INJURY.**

**CAUTION! PLACING OBJECTS AGAINST OR ON TOP OF THE DISPENSER CAN CAUSE PERSONAL INJURY.**

1. Make sure that the stand is positioned on a level surface and lock the brakes of the four swivel casters (refer to Figure 11).
2. Make sure the stand stays in position while operating the **Dispenser**.

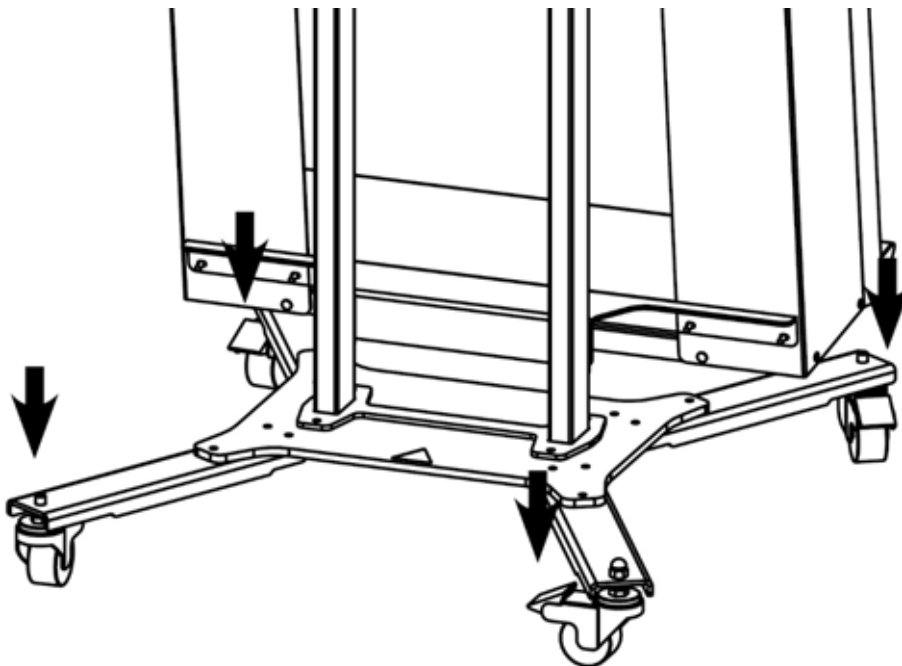

Figure 11 Swivel Casters with Brakes

## 4.4 DISPENSER CONTROLS LAYOUT AND OPERATION

### 4.4.1 Dispenser Controls

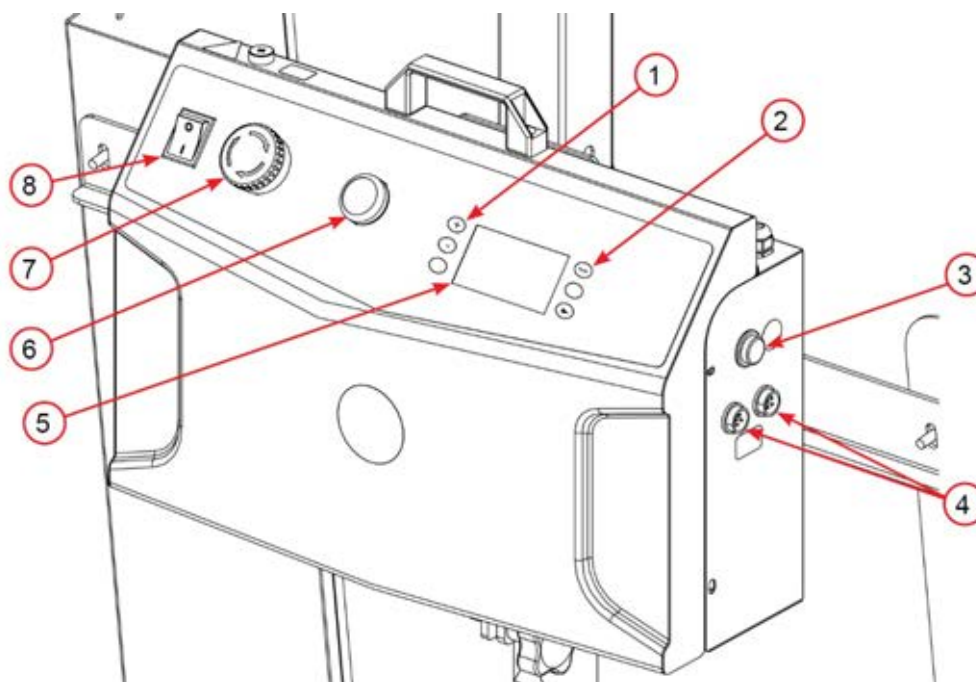

Figure 12 Dispenser Controls

LEGEND	
Item No.	Description
1	<b>Length and Speed Adjustment Buttons</b> - By using the (-) and (+) buttons, the preferred void fill paper length can be set. The bottom button will allow the user to set the dispensing speed.
2	<b>Mode, Output Length, and Dispense Buttons</b> - These buttons will allow the user to toggle through the dispensing modes, change between Imperial and Metric units, and manually dispense paper void fill.
3	<b>Load Void Fill Button</b> - By using this button the machine will slowly advance the forming gears allowing the user to load the paper void fill more easily.
4	<b>Foot Switch Connection</b> – This is connected to the foot switch (not shown); the foot switch is used to produce material output.
5	<b>Controls Display</b> - This display shows the predefined Void Fill length and Program Details
6	<b>Reset Button</b> - This switch is pressed after the E-Stop Button has been released or after initial power up.
7	<b>Emergency Stop Button (E-Stop)</b> - This red button disables the drive assembly when pushed. <b>Note: To reset the E-Stop, twist and release it and then press the reset button.</b>
8	<b>ON/OFF Power Switch</b> – This push button controls power to the system.



#### 4.4.2 Dispenser Modes of the X-Fill Pro



This Dispenser type is provided with electrically driven Paper Feed Wheels. After the paper is dispensed through the Output Chute, the string of void fill paper will be separated automatically by a blade behind the Output Chute.

**WARNING! KEEP CLOTHING, HAIR, AND JEWELRY OUT OF THE DISPENSER ENTRANCE AND OUTPUT CHUTE. KEEP HANDS AWAY FROM THE PAPER WHEN THE DISPENSER IS OPERATING. PAPER EDGES MAY CUT THE SKIN.**



**WARNING! AT NO TIME SHOULD ANYONE REACH INTO THE MACHINE. MOVING PARTS CAN CRUSH AND CUT. DO NOT OPERATE WITH GUARDS REMOVED.**

#### 4.4.3 Feeding Paper into the Dispenser and Operating the Several Dispenser Modes.

1. Ensure the **Foot Switch Plug** is properly connected to the **Dispenser** Control Box Foot Switch connections. Make sure the Foot Switch round nut is secured properly by turning the nut clockwise.
2. Ensure the **IEC**, Main Power Connection, is properly connected to the **Dispenser** Control Box and wall socket.
3. Ensure the **Emergency Stop button** is not pressed.
4. Turn the **Dispenser** controls **ON** by switching the **I/O Main Switch** on the **Control Box** to the **[I]** position. The **Main Switch** illuminates when the **Dispenser** Controls are activated.
5. Push the **Reset Button** (refer to Figure 12).
6. Select the preferred **Dispenser Mode** by switching the **Mode Selector Switch** to the **[I]** or **[II]** position (refer to Figure 12).
7. Place the **Paper Bundel** in the **Bundle Holder** (refer to Figure 13).
8. Remove the straps around the **Paper Bundle** by using hand scissors.



**Pay attention when using hand tools such as knives, scissors, etc., due to the risk of cutting.**

9. Lift some sheets of paper from the **Paper Bundle** and fold the beginning of the sheets into an arrow using at least 3 sheets (see below).
  - ❖ How to fold the paper into an arrow. The arrow length should be approx. 3 sheets long (1 sheet is 11.0 in.). The front tip must not be wider than 1.0 in. (3.0cm).

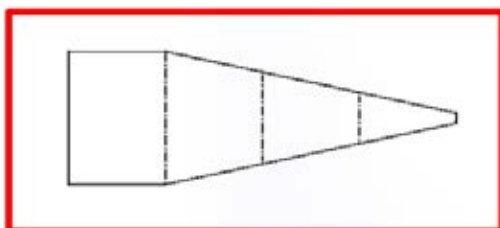

10. Insert the folded arrow of paper sheets into the **Dispenser Input Chute** (refer to Figure 13).
11. Push the folded arrow of paper sheets towards the **Dispenser Feeding Wheels** (refer to Figure 13).
12. Hold the sheets down at the back end of the **Dispenser Input Chute** to avoid the paper falling out of the **Dispenser Input Chute**.
13. Press the **Feed-In Button** on the **Dispenser Control Box**. The driven **Dispenser Feeding Wheels** will engage and start pulling the paper into the **Dispenser**.
14. Release the **Feed-in Button** on the **Dispenser Control Box** as soon as the string of paper void fill is visible at the **Dispenser Output Chute** (refer to Figure 13).

**The Dispenser is ready for operation dispensing the preferred amount of void fill paper by selecting one of the Dispenser Modes.**

#### **4.4.4. Feeding Mode Operation**

1. To engage **Free Mode**, press the mode selector button until the LCD display reads **MODE: FREE**.
2. In **Free Mode**, the **Dispenser** will dispense a string of void fill paper for as long as the **Foot Switch** or **PLAY** button is pressed. When the **Foot Switch** or **PLAY** button is released, the **Dispenser** will stop moving paper, cut the paper, and the display will show the length of material dispensed in either feet or meters depending on the length mode selected. The **Dispenser** will cut the string of void fill paper allowing the operator to remove the material from the chute.
3. The speed that the void fill paper is dispensed can be adjusted by pressing the **SPEED** button. Selection can be made from 1-9 with 1 being the slowest and 9 being the fastest.
4. In **Free Mode**, the (+) and (-) buttons will not change any function or operation.



**The Dispenser will dispense a string of paper void fill as long as the Foot Switch is pressed down. Release the Foot Switch to stop dispensing paper. The Dispenser will automatically cut the void fill paper to length.**

#### **4.4.5. Memory Mode Operation**

1. To engage **Memory Mode**, press the mode selector button until the LCD display reads **MODE: MEMORY**.
2. In **Memory Mode**, the Operator will press the **Foot Switch** or **PLAY** button and hold it while the **Dispenser** processes paper in the same way as **FREE MODE**. The **Dispenser** will remember the length that was processed, and every subsequent press will dispense the same length.
3. To reset the memory, the Operator will need to cycle through the modes back to **MEMORY MODE**.
4. The speed that the void fill paper is dispensed can be adjusted by pressing the **SPEED** button. Selection can be made from 1-9 with 1 being the slowest and 9 being the fastest.



**The Dispenser will dispense a string of paper void fill as long as the Foot Switch is pressed down. Release the Foot Switch to stop dispensing paper. The Dispenser will automatically cut the void fill paper to length.**

#### 4.4.6. Pre-Set Mode Operation

1. To engage **Pre-Set Mode**, press the mode selector button until the LCD display reads **MODE: PRESET**.
2. In **Pre-Set Mode**, the **Dispenser** will dispense a string of void fill paper equal to the length selected on the LCD display each time the **Foot Switch** or **PLAY** button is pressed; there is no need to hold the **Foot Switch** or **PLAY** button. To adjust length, press the (+) or (-) button to change the paper string length by one foot or 0.1 meter depending on the length mode selected. The **Dispenser** will cut the string of void fill paper allowing the operator to remove the material from the chute.



**The Dispenser will dispense a string of paper void fill to the pre-set length when the Foot Switch is pressed down. The Dispenser will automatically cut the void fill paper to length.**

#### 4.4.7. Cut and Hold Mode Operation

1. To engage **Cut & Hold Mode**, press the mode selector button until the LCD display reads **MODE: CUT&HOLD**.
2. In **Cut & Hold Mode**, the **Dispenser** will dispense a string of void fill paper equal to the length selected on the LCD display each time the **Foot Switch** or **PLAY** button is pressed; there is no need to hold the **Foot Switch** or **PLAY** button. Once the initial press of the **Foot Switch** or **PLAY** button happens the bottom line on the LCD display will read **CUT&HOLD ON**. To adjust length, press the (+) or (-) button to change the paper string length by one foot or 0.1 meter depending on the length mode selected. Once the **Dispenser** has dispensed the void fill paper the operator can remove it from the chute. When this paper is removed the **Dispenser** will automatically dispense a new string of void fill paper. This will continue until the operator presses the **Foot Switch** or **PLAY** button; this will turn off **CUT & HOLD MODE**.
3. The speed that the void fill paper is dispensed can be adjusted by pressing the **SPEED** button. Selection can be made from 1-9 with 1 being the slowest and 9 being the fastest.



**The Dispenser will dispense a string of paper void fill to the pre-set length when the Foot Switch is pressed down. The Dispenser will automatically cut the void fill paper to length. The Dispenser will continue to dispense a string of paper void fill every time the operator removes a string of paper void fill until the foot switch is pressed a second time.**

### 4.4.8. Program Length Mode

1. Switch the **Dispenser Mode Selector Switch** to **[II]**. The **Controls Display** will show two digits.
  - ❖ Position **[II]** is the **Program Length Mode**. In this mode the **Dispenser** produces a predefined length of void fill paper after pushing and releasing the **Foot Switch**.
2. Set the preferred length of the paper void fill string by using the **(+)** and **(-)** push buttons.
  - ❖ **In Metric Units setting** (refer to Figure 14): The digits representing the length of the string of void fill paper are in **meters**. For example, if the display shows 0.5, the preferred string of void fill paper is set to 0.5m [ $\pm 10\%$ ].
    - i. **The minimum possible programmable length of void fill paper is 0.5m. The maximum possible programmable length of void fill paper is 9.9m.**
  - ❖ **In Imperial Units setting** (refer to Figure 14): The digits representing the length of the string of void fill paper are in **inches**. For example, if the display shows 04, the preferred string of void fill paper is set to 40 in. [ $\pm 5\%$ ].
    - i. **The minimum possible programmable length of void fill paper is 02 in. The maximum possible programmable length of void fill paper is 99 in.**



**In Program Length Mode the Foot Switch only needs to be activated for a short period of time. After tapping the Foot Switch the Dispenser Feeding Wheels will engage the paper and dispense the pre-programmed length of void fill paper.**

**The Dispenser will automatically cut the string of void fill paper to length.**

**Tap the Foot Switch again to start a new Feed Cycle.**

**NOTE:** In case the actual dispensed length of void fill paper is not equal to the predefined length, which is set in the Controls Display, refer to Section 4.5.

**NOTE:** To verify if the Dispenser controls are set to METRIC or IMPERIAL:

- ❖ In the Metric unit setting the length will be displayed as "00.0 m"; **m** designates meter.
- ❖ In the Imperial unit setting length will be displayed as "000 ft"; **ft** designates feet.



**The Dispenser is for intermittent use and should not be run continuously for more than one minute.**

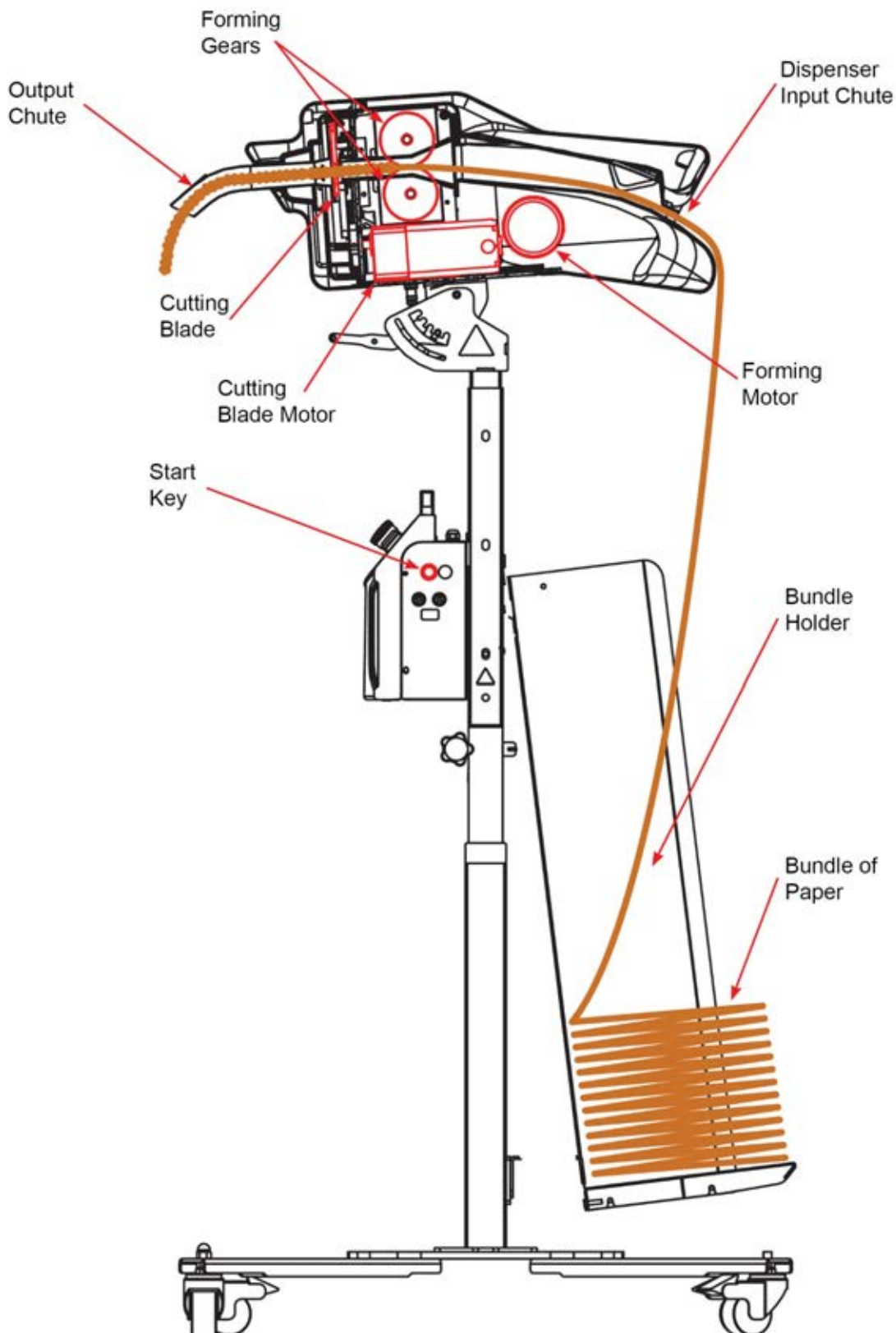

Figure 13 Paper Path

## 4.5 DISPENSER UNITS SETTING AND PAPER FEED LENGTH ADJUSTMENT

### 4.5.1 Changing Dispenser Units Setting

1. Switch the **I/O Main Switch** to [I] (**On**) position (refer to Figure 14).
2. To toggle back and forth between Metric and Imperial modes press the "**ft/m**" button to the right of the LCD display. The current mode will be shown on the length line of the display.
3. In Imperial the length will be displayed as "**000 ft**"; in Metric the length will be displayed as "**00.0 m**."
4. Press the **RESET** Button.

### 4.5.2 Adjusting the Feed Length of the String of Void Fill Paper.

Depending on the paper type used, the Dispenser Feed Length for Program Length Mode may need to be changed from the factory setting. To adjust the void fill paper string feed length, follow the steps below.

1. Switch the **I/O Main Switch** to [I] (**On**) position (refer to Figure 14).
2. Length can be adjusted at any time by pressing the (+) or (-) buttons to the left of LCD display. The length will be adjusted by one ft. in **Imperial** mode and 0.1 m in **Metric** mode.
3. Holding the button down will advance the selection and change length values faster.
4. Press the **RESET** Button.

*\*Repeat the process as described in Section 4.5.2 in case the feed length needs to be adjusted.*

*The Dispenser is now set and ready for use.*

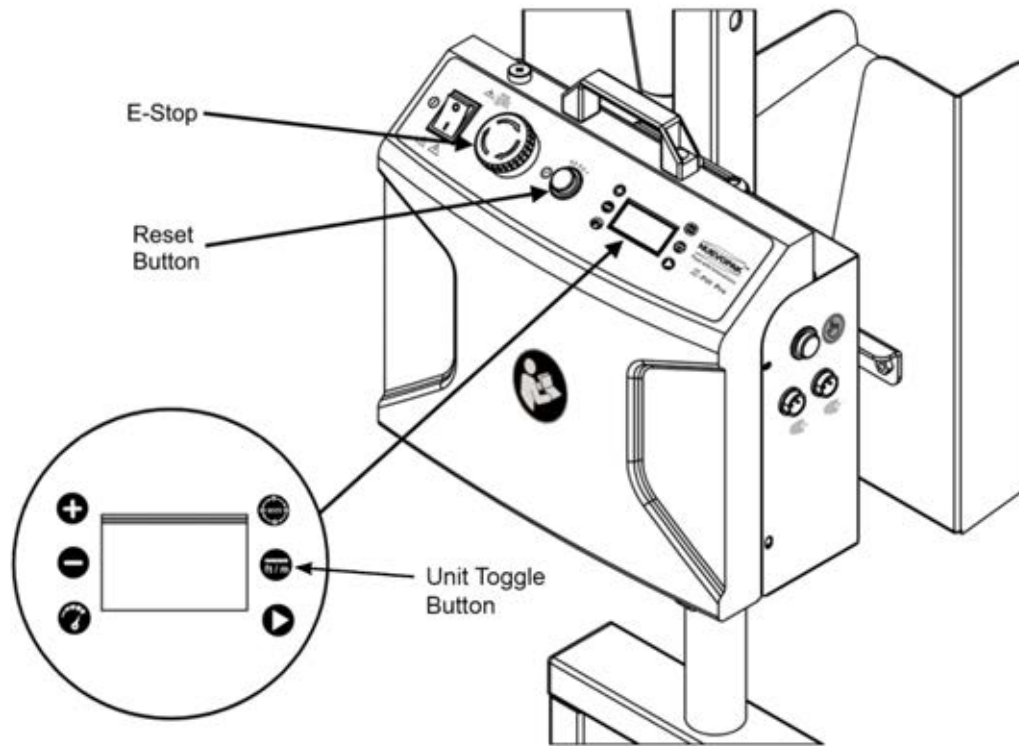

Figure 14 Units Setting

## 4.6 MOVING/STORING THE DISPENSER

### 4.6.1 Moving the Dispenser on Floor Stand

1. Position the **I/O Main Switch** to **O [OFF]** and unplug the Main Power Cord from the Control Box. Store the Main Power Cord.
2. Unplug the **Foot Switch Plug** from the Control Box by releasing the round nut by turning it counterclockwise. Store the Foot Switch.
3. Remove and store the paper bundle.
4. **Moving the Dispenser on Floor Stand:** Unlock the brakes of the four (4) swivel casters. The **Dispenser** can be wheeled to a new location.



**WARNING! DISPENSER ON FLOOR STAND IS TOP HEAVY. HOLD THE STAND WHILE MOVING AND AVOID OBSTACLES ON THE FLOOR AS TIPPING MAY OCCUR.**

### 4.6.2 Storing the Dispenser Void Fill Paper System

1. Store components in the original packaging in a dry indoor area up off the ground on a shipping pallet or equivalent.



## Chapter 5 Dispenser Maintenance

### 5.1 INSPECTION, MAINTENANCE, AND REPAIR



**WARNING! THE OPERATOR MAY NOT PERFORM ANY MAINTENANCE OR REPAIR PROCEDURES OTHER THAN THOSE THAT ARE WRITTEN AND SPECIFIED UNDER “OPERATOR WEEKLY INSPECTION INTERVAL” AND IN THE SECTION “TROUBLESHOOTING” WHICH ARE SPECIFICALLY POINTED OUT TO THE OPERATOR IN THIS USER MANUAL.**



**CAUTION! IN THE EVENT OF A DEFECT, OR IF THE OPERATION OF THE DISPENSER DIFFERS FROM THE DESCRIPTIONS IN THIS USER MANUAL, TURN THE I/O MAIN SWITCH TO O [OFF] AND DISCONNECT THE MAIN POWER CORD PLUG FROM THE MAIN POWER UNTIL THE UNIT CAN BE INSPECTED BY A TRAINED NUEVOPAK, AN IPG COMPANY, REPRESENTATIVE OR QUALIFIED SERVICE PERSONNEL.**

### 5.2 OPERATOR WEEKLY INSPECTION INTERVAL

This section contains the following **Operator** procedures:

1. Weekly Inspection Interval

**CHECK IF:**



- Covers are properly secured and not damaged.
- Dispenser cables are not cut, broken, or damaged
- Cords or plugs are not damaged
- Dispenser and accessories components are secured well
- All controls and indicators function properly



**CAUTION! DO NOT OPERATE ANY SYSTEM WITH A DAMAGED CORD OR PLUG, OR AFTER THE SYSTEM MALFUNCTIONS OR IS DROPPED OR DAMAGED IN ANY MANNER. RETURN THE SYSTEM TO THE NEAREST AUTHORIZED SERVICE FACILITY FOR EXAMINATION, REPAIR, AND ELECTRICAL OR MECHANICAL ADJUSTMENTS, IF REQUIRED.**

## 5.3 PREVENTIVE MAINTENANCE INTERVAL

This section contains the following **Qualified Service Personnel** procedures:

1. Preventive Maintenance. Every 6 months or after usage of 60 bundles of paper



**Preventive Maintenance inspections are done to make sure the Dispenser preforms at its expected level. They are performed at intervals of every 6 months or after usage of 60 bundles of paper.**



**WARNING! ONLY QUALIFIED SERVICE PERSONNEL WHO HAVE BEEN TRAINED BY A NUEVOPAK OR IPG COMPANY REPRESENTATIVE ARE ALLOWED TO PERFORM MAINTENANCE AND REPAIR PROCEDURES.**



**WARNING! BEFORE ANY MAINTENANCE: SWITCH THE I/O MAIN SWITCH TO O [OFF] POSITION AND DISCONNECT THE MAIN POWER CORD PLUG FROM THE MAIN POWER.**



**BEFORE PERFORMING MAINTENANCE PROCEDURES READ AND THOROUGHLY UNDERSTAND THE SAFETY INSTRUCTIONS IN THIS USER MANUAL (REFER TO SECTION 2.2).**

2. The void fill paper created by the **Dispenser** is intended to be used only as packaging material.
3. The operator may not perform any maintenance or repair procedures other than those specified in the section OPERATOR WEEKLY INSPECTION INTERVAL above.
4. Changes or modifications not expressly approved by **Nuevopak**, an **IPG Company**, Corporation could void the user's authority to operate the equipment.
5. In the event the maintenance required is beyond the scope outlined in this user manual, contact **Nuevopak** or other **IPG Company technical** support for a qualified service technician.

# Chapter 6 Troubleshooting

## 6.1 TROUBLESHOOTING

The **Dispenser** is intended to be used for converting paper into void fill paper. Repairs or modifications should be done by a **Nuevopak**, an **IPG Company**, authorized representative or trained Service Technician (refer to Technical Support).

Problem	By whom	Possible Causes	Solutions
There is no power to the Controls – the <b>Control Box I/O Main Switch</b> does not illuminate.	Operator	1. The <b>I/O Main Switch</b> is positioned to <b>[O] OFF</b> position.	Turn the <b>I/O Main Switch</b> to the <b>[I] ON</b> position and <b>Reset</b> the Dispenser Controls.
		2. <b>IEC Main Power Cord Connection</b> or Power Cord Plug is unplugged from the <b>Control Box</b> or at the <b>Wall Socket</b> .	Verify the <b>IEC Main Power Cord Connection</b> is plugged into the <b>Control Box</b> and the <b>Power Cord Plug</b> is plugged into a properly rated <b>Wall Socket</b> .
		3. The Main Power is interrupted.	Verify if there is Main Power to other equipment in the packing area. Contact <b>Technical Support</b> in case the Main Power is interrupted.
	Service Technician	4. <b>Control Box Main Fuse</b> is defective.	Turn the <b>I/O Main Switch</b> to the <b>[O] OFF</b> position. Disconnect the <b>Main Power Cord Plug</b> from the main power. Contact <b>Technical Support</b> to replace the Main Fuse.
		5. A cable reel is in use.	Replace the cable reel with an extension cable with a wire gauge of at least 14 AWG (1.5mm <sup>2</sup> ) with a maximum length of 3.3 ft. (6m).
		6. Electrical or Mechanical defect.	Contact your authorized distributor or <b>Nuevopak</b> , an <b>IPG Company</b> , representative.
The length of the string of void fill paper is not equal to the programmed length.	Operator	1. The <b>Dispenser Mode Selector Button</b> is in the incorrect position.	Position the <b>Dispenser Mode Selector Switch</b> to the preferred mode.
		2. The Dispenser Units Setting or Paper Feed Length adjustment is set incorrectly.	Contact your <b>Technical Support</b> to have the Dispenser Controls calibrated correctly according to Section 4.5 (Dispenser Units Setting and Paper Feed Length).

Problem	By whom	Possible Causes	Solutions
No Paper Feed using the <b>Foot Switch</b> or <b>Feed-In Button</b> – the <b>I/O Main Switch</b> is positioned to <b>[I] ON</b> and is illuminated.	<b>Operator</b>	1. The Paper <b>Feed Wheels</b> engage when pressing the <b>Foot Switch</b> - The <b>Paper Bundle</b> is empty.	Reload the Dispenser with a new <b>Paper Bundle</b> (refer to Section 4.4.3).
		2. The Paper <b>Feed Wheels</b> engage when pressing the <b>Foot Switch</b> - The Paper is torn at the <b>Input Chute</b> or at the paper <b>Feeding Wheels</b> .	Reload the Dispenser with paper (refer to Section 4.4.3).
		3. The Paper <b>Feed Wheels</b> <u>DO NOT</u> engage when pressing the <b>Foot Switch</b> but <u>DO</u> engage when pushing the <b>Feed-In Button</b> - The <b>Foot Switch Connection</b> is not properly connected.	Make sure the <b>Foot Switch Plug</b> is properly connected to the <b>Control Box Connection</b> by turning the <b>round nut</b> clockwise till correctly fixated.
		4. The Paper <b>Feed Wheels</b> <u>DO NOT</u> engage when pressing the <b>Foot Switch</b> but <u>DO</u> engage when pushing the <b>Feed-In Button</b> – The used <b>Foot Switch Connection</b> is not properly connected.	Move the <b>Foot Switch Plug</b> to the spare <b>Control Box Foot Switch Connection</b> (refer to Figure 12). In case the Dispenser works properly after switching to another Foot Switch Connection, contact <b>Technical Support</b> .
		5. The Paper <b>Feed Wheels</b> <u>DO NOT</u> engage when pressing the <b>Foot Switch</b> and <u>DO NOT</u> engage when pushing the <b>Feed-In Button</b> – The <b>Circuit Breaker</b> is engaged (push button in high position) due to <b>Feed Wheels</b> overload.	Turn the <b>I/O Main Switch</b> to the <b>[O] OFF</b> position. Wait for 3 to 5 minutes. Turn the <b>I/O Main Switch</b> to the <b>[I] ON</b> position. Press the push button from the <b>Circuit Breaker</b> (refer to Figure 12). In case the push button from the <b>Circuit Breaker</b> moves back in high position, contact <b>Technical Support</b> .
		6. The Paper <b>Feed Wheels</b> <u>DO NOT</u> engage when pressing the <b>Foot Switch</b> and <u>DO NOT</u> engage when pushing the <b>Feed-In Button</b> – The <b>Emergency Stop Button</b> is pressed.	Release the <b>Emergency Stop</b> by turning the <b>Red Button</b> clockwise. <b>Reset</b> the Dispenser (refer to Figure 12)

Problem	By whom	Possible Causes	Solutions
No Paper Feed using the <b>Foot Switch</b> or <b>Feed-In Button</b> – the <b>I/O Main Switch</b> is positioned to <b>[I] ON</b> and is illuminated. - Continued		7. The Paper <b>Feed Wheels</b> <u>DO NOT</u> engage when pressing the <b>Foot Switch</b> and <u>DO NOT</u> engage when pushing the <b>Feed-In Button</b> – The <b>Dispenser Controls Connection Plug</b> is not properly tightened.	Turn the <b>I/O Main Switch</b> to the <b>[O] OFF</b> position. Make sure that the <b>Dispenser Controls Connection Plug</b> is properly connected to the <b>Control Box Connection</b> by turning the <b>round nut</b> clockwise till correctly fixated (refer to Figure 12). Turn the <b>I/O Main Switch</b> to the <b>[I] ON</b> position and <b>Reset</b> the Dispenser Controls (refer to Figure 12)
	<b>Service Technician</b>	8. The Paper <b>Feed Wheels</b> <u>TRY</u> to engage when pressing the <b>Foot Switch</b> or when pushing the <b>Feed-In Button</b> – The Paper is jammed in the <b>Feed Wheels</b> or <b>Dispenser Output Chute</b> .	Turn the <b>I/O Main Switch</b> to the <b>[O] OFF</b> position. Disconnect the <b>Main Power Cord Plug</b> from the main power. Contact <b>Technical Support</b> .
		9. The Paper <b>Feed Wheels</b> <u>DO NOT</u> engage when pressing the <b>Foot Switch</b> but <u>DO</u> engage when pushing the <b>Feed-In Button</b> – The <b>Foot Switch used</b> is defective.	Turn the <b>I/O Main Switch</b> to the <b>[O] OFF</b> position. Disconnect the <b>Foot Switch Plug</b> from the <b>Control Box Connection</b> and install a new <b>Foot Switch</b> (refer to Figure 12). In case no new <b>Foot Switch</b> is available, contact your authorized distributor, <b>Nuevopak</b> , or <b>IPG Company</b> representative.
		10. Electrical or Mechanical defect.	Contact your authorized distributor, <b>Nuevopak</b> , or <b>IPG Company</b> representative.
The cutting blade is not functioning as expected or not functioning at all.	<b>Service Technician</b>	1. Cutter Failure	Contact your authorized distributor, <b>Nuevopak</b> , or <b>IPG Company</b> representative.

